



**MAKE YOU
SAFER AND SMARTER**

**SCISSOR LIFTS
ZS0607/ZS0607W**

ZS0607 / ZS0607W

Models	ZS0607		ZS0607W	
	US	Metric	US	Metric
Measurements				
A Working height maximum*	25 ft 7 in	7.8 m	25 ft 7 in	7.8 m
A ₁ Platform height maximum	19 ft	5.8 m	19 ft	5.8 m
B Length-stowed	6 ft 1 in	1.86 m	6 ft 1 in	1.86 m
C Width	2 ft 6 in	0.76 m	2 ft 8 in	0.81 m
D Height stowed fixed rails	7 ft 2 in	2.18 m	7 ft 2 in	2.18 m
E Platform length -Outside	5 ft 5 in	1.65 m	5 ft 5 in	1.65 m
F Slide-out platform extension deck	2 ft 11 in	0.90 m	2 ft 11 in	0.90 m
G Platform width - outside	2 ft 6 in	0.76 m	2 ft 6 in	0.76 m
H Wheelbase	4 ft 5 in	1.35 m	4 ft 5 in	1.35 m
I Ground clearance-center	2.4 in	0.06 m	2.4 in	0.06 m
J - with pothole guards deployed	0.80 in	0.02 m	0.80 in	0.02 m
Productivity				
Maximum Platform Occupancy **	2	2	1	1
Lift capacity	507 lbs	230 kg	507 lbs	230 kg
Lift capacity - extension deck	265 lbs	120 kg	265 lbs	120 kg
Drive height	full height			
Drive speed - stowed	2.5 mph	4.0 km/h	2.5 mph	4.0 km/h
Drive speed - raised	0.5 mph	0.8 km/h	0.5 mph	0.8 km/h
Gradeability - stowed***	25%			
Turning radius - inside	0			
Turning radius - outside	4 ft 5 in	1.35 m	4 ft 5 in	1.35 m
Max. work angle of inclination	3°/ 1.5°	3°/ 1.5°	3°/ 1.5°	3°/ 1.5°
Raise / lower speed (s)	18/28			
Controls	Proportional			
Drive	Dual front wheel			
Multiple disc brakes	Dual rear wheel			
Tires - solid non-marking	12 x 4.3 in	30.5x11.4cm	12 x 4.3 in	30.5x11.4cm
Power				
Drive Motor	3.3 kw			
Power source	24 V DC (four 6 V 225 Ah batteries)			
Charger	90-240V 25 Amp		90-240 V 25 Amp	
Hydraulic system capacity	2.6 gal	10 L	2.6 gal	10 L
Weight****				
	3263 lbs	1480 kg	3307 lbs	1500 kg

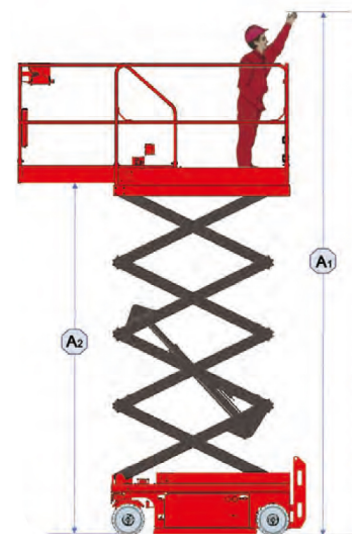
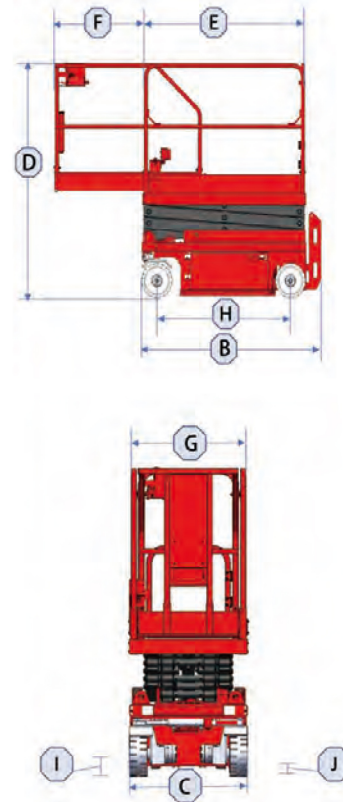

Standard Equipment

- Auto brake system
- Manual braking release
- Emergency lowering
- Lanyard attachment points
- Emergency stop at both platform and ground controls
- Hour meter
- Drive flashing beacons
- Motion alarm
- Electronic horn
- Descent alarm
- Descent protection
- Charging position regulation
- Tilt level sensor with audible alarm
- Overload protection system
- On-board diagnosis system
- Oil pipeline explosion-proof
- Pothole protection
- Safety brackets

Options & Accessories

- AC power to platform
- Airline to platform
- GPS module
- Obstacle alarm
- AGM maintenance free batteries
- Charging protection
- Platform flashing beacons